

Political Incoherence: an application of k -uncolourable hypergraphs to the theory of democracy

T. Nicholson

Laboratory for Logic and Experimental Philosophy
Simon Fraser University
Burnaby, BC, Canada

April 30, 2001

Abstract *Preservationist paraconsistent logicians have demonstrated the utility of k -uncolourable hypergraphs when it comes to formalizing non-trivial but classical inference from inconsistent premise sets. Here it is shown how this application can be extended to the deontically dual political context in which elected officials form unified policies which putatively represent incohesive interest groups. By exploiting the logical duals of k -uncolourable hypergraphs, a non-statistical model for a democratic polling technique is designed whose aim is to preserve electoral representativeness through deliberative legislative processes of policy formation. Moreover, it is proven that the mathematical technology required to instantiate the polling technique exists, and would not be too difficult to implement. In particular, it is shown to be a theorem that $\forall k > 1, \forall j > k, \exists H : H$ is a hypergraph with $\chi(H) = k + 1$, and $\forall E \in H$, the restriction of H to $\cup H - E$ has chromatic number $k - 1$.*

Keywords: paraconsistent logic, democracy, k -uncolourable hypergraph, transversal hypergraph

1 Introduction

It is perhaps a truism of political theory that the integrity of a democracy can be safeguarded only insofar as the representativeness of its governing bodies can be ensured. In general, the less representative a legislature is, the more opportunity there exists for private inter-

est groups to affect public policy for the purpose of furthering their own aims. Arguably, the democratic changes in Athens of 462 were designed to stop this kind of dilution of the sovereignty of the popular assembly, the *ekklesia*, by requiring the random selection of a 500 membered body, the *boule*, whose main function was to oversee what matters were to appear for debate in the public forum [2]. The idea was that each of the local *demes*, the constituent villages of Attica, was to supply a number of *bouleutai* to the *boule* which was considered proportionate to the size of its population. Thus, as the *boule* began to be characterized by a preponderance of wealthy and familiarly-related members, we find historical evidence that ways had been discovered to circumvent the randomness of the selection procedure. Nevertheless, in theory we can say that the *boule* represented the Athenian electorate, since it consisted of a randomly selected transversal for the hypergraph H of its demes.

Definition 1.1 *A hypergraph is any finite non-empty set H of finite non-empty sets E , where $\cup H$ is the set of vertices of H , and $\{E_i\}$ is the set of H -edges.*

Definition 1.2 *Let H be a hypergraph, and let S be a set. Then S is a transversal for H iff $\forall E \in H, S \cap E \neq \emptyset$ (see Figure 1).*

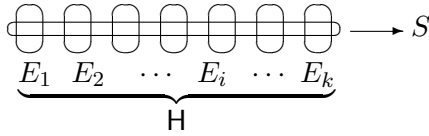

Figure 1: A transversal S for a hypergraph H .

In contrast, modern democracies elect what amounts to the transversal of which their government mainly consists. But, unless wealth selects uniquely for competence, it is arguable that one consequence of this contrast is that modern democracies tend to favour less representative governments, in that wealthier citizens are more likely to popularize their views among an electorate, and are therefore more likely to gain access to governing positions. Indeed, despite the probable falsehood of the claim that lack of membership in a group always entails an inability to adequately represent that group’s political interests, the extent to which a legislature lacks an efficient medium for the dissemination of incohesive electoral preferences *does* seem to suggest a kind of measure for the *un*-representativeness of its policies. Similarly then, among other conditions which tend to mitigate against the representativeness of a legislature, one could include such factors as a penchant for sophistry, bickering, and miscommunication on the part of elected officials. In effect, what these remarks suggest is that mere “rep-by-pop” is an insufficient basis for the construction of a democratic legislative process—that there is a kind of *dynamic* representativeness, which really ought to be preserved in a legislature’s deliberative processes of policy formation.

To illustrate, a *level of divisiveness* will be introduced which can be used to measure the relative difference between, for example, the number of mutually incohesive political perspectives with respect to some issue, among an electorate, and the number of possible outcomes for that issue which are being adequately, or effectively debated in a legislative house. The point is thus that if the size of the

former variable is significantly larger than that of the latter, then any policy formed as a result of such debate is to that extent lacking in responsiveness to the public will. Indeed, as when for example a single party dominates the legislature, not only is doubt thereby cast upon the representativeness of its decisions, but the putative democratic virtue of public political debate is rendered moot—especially within a system in which party members cannot with impunity fail to “tow the party line”. In these ways, the structure of a legislative system may negatively affect its representativeness. Therefore, *prima facie*, a democratic scheme may be judged better or worse accordingly as it serves or does not serve to diminish such effects.

Suggestively, there appears to be a dual structural similarity between what may be construed as the deontology of the socio-political phenomenon under discussion and that of (classical) inference from (classically) inconsistent premise sets: Just as we ought to restrict arbitrary inference from an inconsistent database, or else lose the potential epistemic good of inferences to be drawn from it, so too ought we to try to minimize the difference between the number of competing political perspectives in an electorate, and the number of vessels provided in government for the representation of these perspectives. For although arbitrary inference from an inconsistent database is (classically) permissible, it doesn’t follow that any such inference ought to be made, or that any good will come of it. Similarly, just because a policy is decided upon by a democratically *formed* body, and is consequently legal, it doesn’t follow that the policy itself is representative, or that it ought to have been made.

Fortunately, some progress has been made on the paraconsistent side of this analogy. Preservationist logicians have shown that by measuring what is called the *level of (in)coherence* of a set Σ of sentences, it is possible to restrict inferences to those sentences which, when added to Σ , do not necessarily trivialize the resulting set [4]. This strategy exploits the notion of what in the logic literature has

been called a *k-trace*—an object which for our purposes we can understand simply as a *k-uncolourable hypergraph*.

Definition 1.3 *Let Σ be a set. Let $k \in \mathbb{Z}^+$. Then the set of all k -partitions of Σ , $\Pi_k(\Sigma) = \{\pi = \{c_i\} \mid \cup_{i=1}^k c_i = \Sigma, \text{ and } \forall i, j (1 \leq i \neq j \leq k), c_i \cap c_j = \emptyset\}$.*

Definition 1.4 *Let H be a hypergraph. Then the chromatic number of H , $\chi(H) = \min \{j \in \mathbb{Z}^+ \mid \exists \pi \in \Pi_j(\cup H) : \forall c_i \in \pi, \forall E \in H, E \not\subseteq c_i\}$.*

The above definition implies that hypergraphs with singleton edges have either no or, arbitrarily high, chromatic number. We therefore restrict our attention to hypergraphs without singleton edges.

Definition 1.5 *Let H be a hypergraph with $k \in \mathbb{Z}^+$. Then H is k -uncolourable, if $\chi(H) > k$. H is k -colourable, else.*

Definition 1.6 *Let Σ be a set of sentences of some language Φ . Then the coherence level of Σ , $l(\Sigma) = \min \{j \in \mathbb{Z}^+ \mid \exists \pi \in \Pi_j(\Sigma) : \forall c \in \pi, c \not\vdash \perp\}$. If j does not exist then set $l(\Sigma) = \infty$.*

Definition 1.7 *Let Σ be a set of sentences of some language Φ , let $\alpha \in \Phi$, and let $n \in \mathbb{Z}^+$. Then Σ n -forces α ($\Sigma \vdash_n \alpha$) iff $\exists H \subseteq \wp(\Sigma) : \chi(H) > n$, and $\forall E \in H, E \vdash \alpha$.*

It is easy to see that “level-forcing” preserves coherence level; its teleology being to minimize the difference between the level of the input, and that of the output. But, dually, this is exactly the structure of what we should want from a democratic political system: conceptualizing the input to a democratic process as an electorate, and the output as the members of a legislative body who *effectively* represent the interests of their constituents, we should want the level of divisiveness of the output to be at least as great as that of the input.

Whence this article presents a model for a polling technique which is imbued with a structural impetus for the dynamic representative-

ness of legislative decisions. The technique exploits a logically dual characterization of k -uncolourability for hypergraphs, which yields as a consequence the independently definable class of objects called *k-chines*. These objects form the basis for the polling procedure. In passing, it ought perhaps to be mentioned that this approach presents a departure from the kinds of formal strategies conventionally used in political science. In that context, the formalisms tend to be drawn primarily from theories of games, social choice and multi-dimensional geometries, with a focus on such issues as the equilibria of competing strategies. In contrast, this article uses a theory of extremal sets to model potential and desirable transfers of information among groups of elected officials.

2 *k*-chines

We establish the main lemmas required to provide a logically dual characterization of k -uncolourability for hypergraphs.

Definition 2.1 *Let H be a hypergraph. Then the transversal hypergraph TrH for H is the set of all minimal transversals for H .*

Definition 2.2 *Let $\Phi = \{\alpha_i\}$ be a denumerable language with \wedge and \vee . Let $H \subseteq \wp(\Phi)$ be a hypergraph. Then the formulation of H , $f(H) = \vee[\wedge[E \in H]]$. The dual formulation of H , $f^\Delta(H) = \wedge[\vee[E \in H]]$.*

Theorem 2.3 $\forall H, TrTrH \subseteq H$ [5].

Assume not. Let E be in $TrTrH$, where $E \notin H$. Then since $\forall E' \in H, E'$ is a transversal for $TrH, E' \not\subseteq E$. I.e., $\exists E'' \in TrH, E'' \cap E = \emptyset$, which is absurd.

Definition 2.4 *Let H be a hypergraph. Then H is simple if inclusion minimal—i.e., if H is a clutter, Sperner system, or antichain.*

Theorem 2.5 $\forall H, H \text{ is simple} \Rightarrow H = TrTrH$ [1].

Theorem 2.6 $\forall H, \models f(H) \Leftrightarrow f^\Delta(TrH)$, and $\models f(TrH) \Leftrightarrow f^\Delta(H)$ [5].

Definition 2.7 Let H be a hypergraph, and let $k \in Z^+$. Then H is k -wise intersecting if $\forall B \in \binom{H}{k}$, $\cap B \neq \emptyset$.

Definition 2.8 Let H be a hypergraph. Then H is a k -chine (for $k \in Z^+$) if H is k -wise intersecting, $\cap H = \emptyset$, and $|H| \geq k + 1$.

Definition 2.9 Let H and H' be hypergraphs. Then H subsumes H' , $H \supseteq H'$, if every H -edge contains an H' -edge, and every H' -edge is contained in some H -edge.

H properly subsumes H' , $H \supset H'$, if $H \supseteq H'$, and some H -edge properly contains some H' -edge.

Theorem 2.10 $\forall H, \forall k \in Z^+, H$ is k -uncolourable $\Leftrightarrow TrH$ is a k -chine, and H is a k -chine $\Leftrightarrow TrH$ is k -uncolourable [5].

We prove only the first conjunct, as a strategy for a proof of the second is similar. [\Rightarrow] Assume H is k -uncolourable, but that TrH is not a k -chine. Suppose that $\exists B \in \binom{TrH}{k} : \cap B = \emptyset$. Then $\cup H - [B]$ properly k -colours H . Therefore TrH is k -wise intersecting. Suppose that $|TrH| < k + 1$. Then either TrH is not k -wise intersecting or H is k -colourable, absurd. [\Leftarrow] Assume that H is k -colourable, with $\pi \in \Pi_k(\cup H)$ properly k -colouring H . Then $\cup H - [\pi]$ subsumes a j -tuple B ($j \leq k$) of TrH -edges with $\cap B = \emptyset$. I.e., TrH is not a k -chine.

3 a democratic polling scheme

Assume that the nation's electorate is divided into constituencies in some usual way. Assume further that each constituency elects to a legislative body (call it Parliament) some number of representatives proportionate to its population. While Parliament is thus in a sense composed of a cross-section of eligible voters, the question still remains as to whether or not the decisions made by Parliament adequately

represent the public will. In cases where Parliament is dominated by a single party, the answer to this question is often argued to be "no". Consequently, it is sometimes argued, when a single party does hold a majority of the seats in the legislative assembly, the democratic point of political debate can be moot.

Intuitively, one way around this alleged difficulty is to add an extra layer of structural complexity to the decision-making which occurs in Parliament, by reiterating the "transversal-formation" process by which elected officials essentially gain entry to the house in the first place. In this way, if it is a cross-section of Parliament which ends in shaping the legislative process, the predominance of the occurrence of the members of a single party in Parliament may not immediately entail its domination of policy formation. But to design such an elaboration of the usual democratic scheme, we have to decide at least two things:

- where, structurally speaking, the re-iteration of the transversal-formation process is to occur, and
- what is the hypergraph of which a transversal will be formed?

The treatment of hypergraphs we present suggests that for reasons of practical efficiency, and democratic virtuousness, one possible solution is as follows:

1. Set the *level of divisiveness* of Parliament (P) with respect to an issue I , $d_I(P) = \min \{j \in Z^+ \mid \exists \pi \in \Pi_j(P) : \forall c \in \pi, \forall x, y \in c, x \text{ and } y \text{ favour the same possible outcome with respect to } I\}$.
2. Form a *Parliamentary k -chine* H , $\cup H = P$, where k is set to $d_I(\cup H)$. In effect, this is a decomposition of Parliament into $|H|$ *Parliamentary committees*, every k -tuple collection of which having at least one member of Parliament in common.
3. Stipulate that debate over the issue I is to occur within the Parliamentary committees, after which each member of Parliament will cast a single vote. This stage

is called the *initial vote*. Note that where $d_I(\cup H) = k$, the initial vote induces a k -partition π of $\cup H$ such that $\forall c \in \pi, \forall x, y \in c, x$ and y agree about I .

4. Form TrH , and if $E \in TrH$ is a subset of some cell of π , count each of the initial votes of the elements of E together as a single vote. This stage is called the *final vote*. In fact, these are the only votes that directly affect the final decision about the issue under consideration. In effect we thereby stipulate that all and only members' initial votes will be counted each time their vote is identical with the initial vote of every other member of an element of TrH in which they happen to mutually appear.

Using the theory of k -chines and k -uncolourable hypergraphs, we now describe using more or less formal reasoning how and why it is that this particular scheme achieves the democratic virtues alluded to above. To this end, the first question to consider is perhaps the most basic: "Why k -chines?"

In the general case, it is because H is k -wise intersecting. Consequently, if $k > 1$, then $\forall E \in H, E$ is a transversal for H . I.e., H is self-representative. So by decomposing Parliament into a k -chine where $k = d(\cup H) > 1$, we thus decompose a large representative body into a set of smaller ones which, arguably, provide more fertile grounds for effective debate and communication among elected officials (because they are smaller), but *prima facie* without preventing any particular member of Parliament from communicating with any other. Moreover, since it follows that TrH is k -uncolourable if H is a k -chine, we have that $\exists E \in TrH : \forall x, y \in E, x$ and y agree about I . At the very least then, one advantage of the voting scheme is that some final vote will be counted (assuming that $d_I(\cup H) \leq |\cup H| - 1$; else no parliamentary k -chine can be formed in the first place).

This is, however, peripheral to the main advantage of a polling scheme designed in this

way, which is its structural enforcement of the putative democratic virtue of inter-interest group debate and consensus. For on this scheme, the voting power of individual members of Parliament is filtered to the elements of a set TrH of representative samples from Parliament, any one of which may contain competing party members. In this way, just because a single party controls a majority of Parliamentary seats, it no longer follows directly that it has the ability to dominate the legislative process for the purposes of its own agenda. Indeed, because the structures which have legislative power may contain competing party members, it is in the interest of members of competing parties who appear in the same parliamentary committees to arrive at consensus; else they risk losing their legislative power altogether. To illustrate this point, we exploit the *restriction* of a hypergraph.

Definition 3.1 *Let H be a hypergraph; let $S \subseteq \cup H$. Then the restriction of H to S , $H[S] = \{E \in H \mid E \subseteq S\}$.*

Theorem 3.2 $\forall H, H$ is k -uncolourable $\Rightarrow \forall E \in TrH, H[E]$ is $(k - 1)$ -uncolourable.

Thus, if H is a parliamentary k -chine, then we have that $\forall E \in H$, if $d_I(E) \leq k - 1$, then the members of some subset E' of E will mutually agree on some possible outcome for I , and consequently, some subset of E will have its (final) vote counted. But more than that, it would seem that as $d_I(E)$ decreases, the more likely it is that the number of subsets E' of E which have their final votes counted increases. To see this, consider that if $d_I(E) = 1$, then $\forall E' \in TrH[E], E'$ has its vote counted since in the initial-vote induced $d_I(\cup H)$ -partition π , $\exists c \in \pi : E \subseteq c$. Or, if $d_I(E) = n$, and it turns out that $\chi(TrH[E]) = n$, then it is possible that no subsets E' of E with $E' \in TrH$ will have their final votes counted. Thus, by exploiting various properties of k -chines, it seems possible to design a legislative system imbued with a kind of structural incentive for its constituent committees to reduce their respective levels of divisiveness. Vertex-critical

k -chines therefore seem to be particularly appealing in this context, given that we have that if H is a vertex-critical k -chine, then $\forall E \in H$, $\chi(\text{Tr}H[E]) = k$.

3.1 vertex-critical k -chines

Definition 3.3 H is a vertex-critical k -chine if H is a simple k -chine, and $\forall x \in \cup H, \exists B \in \binom{H}{k} : \cap B = \{x\}$.

Definition 3.4 H is $(k + 1)$ -vertex critical if $\chi(H) = k + 1$, and $\forall S \subset \cup H, S \neq \emptyset \Rightarrow \chi(H[\cup H - S]) < k + 1$.

Theorem 3.5 H is $(k + 1)$ -vertex critical $\Leftrightarrow \text{Tr}H$ is a vertex-critical k -chine, and H is a vertex-critical k -chine $\Leftrightarrow \text{Tr}H$ is $(k + 1)$ -vertex critical.

Theorem 3.6 If H is $(k + 1)$ -critical then $\forall E \in \text{Tr}H$, $\chi(H[E]) = k$.

The proof proceeds mainly by noting that if $\chi(H[E]) > k$, then $\chi(H - (\cup H - E)) \geq k + 1$, which is absurd if H is $(k + 1)$ -vertex critical.

3.2 saturated k -chines

Saturated k -chines also seem well-suited to this context. This is because they are $(k + 1)$ -vertex critical, and also because “ k -chinehood” is not invariant upon the deletion of *any* vertex from *any* edge of a k -chine of this kind. Thus one could argue that saturated chines are *egalitarian*: the presence of *each* member of Parliament, in *each* of the committees to which she or he belongs, is absolutely essential to the preservation of the internal $d_I(\cup H)$ -representative qualities of the committee system. Moreover, on the practical side of the construction, it is a theorem that $\forall k > 1, \forall j > k$, there is a saturated k -chine with j vertices. Because of this, and particularly the recursively algorithmic structure of the proof, a “random-chine-generator” which decomposes Parliament into a saturated chine of the appropriate level and size would presumably not be too inefficient to implement. We don’t go into details of the

computational complexity of such a procedure here, but simply point out that once an isomorphism class of any particular kind of k -chine is known, it remains only to randomly enumerate the $|\cup H|$ members of Parliament in order to decompose the legislature into the elements of a chine of the desired type [3]. We close with the formalisms necessary to establish these last results.

Definition 3.7 Let H be a hypergraph with $E \in H$ and $x \in E$, and let $k \in \mathbb{Z}^+$. Then x is IN_k^E if there is a k -tuple B of H -edges with $E \in B$, and $\cap B = \{x\}$. x is OUT_k^E , else (see Figure 2).

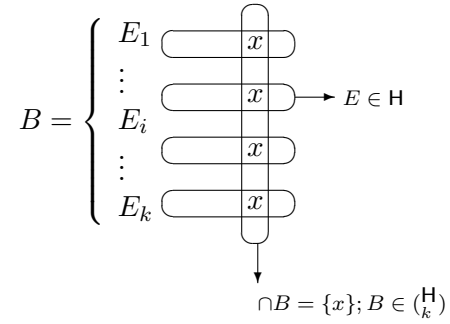

Figure 2: x is IN_k^E

Definition 3.8 H is a weakly saturated k -chine if H is a k -chine, and $\forall E \in H, \forall x \in E$, x is IN_k^E .

Definition 3.9 $H \triangleright H'$ if $H \supset H'$ and $\forall E \in H - H', \forall E' \in H', E \not\supseteq E'$.

Definition 3.10 H is a saturated k -chine if H is a simple k -chine, and $\forall H' \triangleright H, H'$ is not a k -chine.

Theorem 3.11 If H is a saturated k -chine, then H is weakly saturated.

Definition 3.12 $L(H)$ if $\forall E \in H, \chi(H[\cup H - E]) = \chi(H) - 2$.

Theorem 3.13 If H is a saturated k -chine then $L(\text{Tr}H)$.

Assume the antecedent. Suppose that the consequent is false. Then $\exists E \in H : \forall \pi \in \Pi_k(\cup H)$, if exactly E is monochromatic on π , then $E \notin \pi$. Let $H' = H \cup \{\cup H - E\}$. Then H' is k -wise intersecting; else $\exists B \in \binom{H}{(k-1)} : \cap B \cap (\cup H - E) = \emptyset$, in which case $\cup H - (B \cup \{\cup H - E\})$ induces a partition $\pi \in \Pi_n(\cup H)$ on which exactly E is monochromatic, with $E \in \pi$. But also $H' \triangleright H$. So H is not saturated, contrary to assumption.

Theorem 3.14 *If H is k -uncolourable then $\forall E \in TrH, \forall x \in E, x$ is $IN_k^E \Leftrightarrow H[E - \{x\}]$ is $(k-1)$ -colourable.*

Theorem 3.15 $\forall k > 1, \forall j > k, \exists H : H$ is a saturated k -chine with j vertices.

The proof proceeds by an induction on j . For the basis, assume that $j = k + 1$. Then the desired result follows directly from noting that $\binom{k+1}{k} \cong Tr(K_{k+1})$ is a saturated k -chine with j vertices. For the inductive step, assume that $j > k + 1$. by the hypothesis of induction we have that $\exists H : H$ is a saturated k -chine with $j - 1$ vertices. We show how to construct a saturated k -chine H' from H , where H' has j vertices: Let $E \in TrH$ be arbitrary, and where $x \notin \cup H$, form $e = (\cup H - E) \cup \{x\}$. Let C be the hypergraph which results by

1. adding x to any H -edge E' which occurs in a $(k-1)$ -tuple B of H -edges with $\cap B = E$, and
2. adding e to the set system which results from (1)(see Figure 3).

It's easy to see that C is a k -chine with j vertices. Furthermore, since $L(TrH)$, it's not too hard to see that from C we can construct a weakly saturated k -chine D with j vertices, by consecutively deleting vertices in e which are not IN_k^e . Therefore we have that $\exists D : D$ is a weakly saturated k -chine with j vertices, where $D \sqsubseteq C$. So now let F be the largest k -chine such that $F \triangleright D$.

Theorem 3.16 *Either F does not exist, or $\exists F' \sqsubseteq F : F'$ is a saturated k -chine with j vertices, where in particular, $D \subseteq F'$.*

Assume that F exists. Then $F - D \neq \emptyset$, and since D is weakly saturated, $\forall E \in F - D, \forall E' \in D, E \not\subseteq E'$. Let $G = TrTrF$. Then G is a simple k -chine with $G \triangleright D$, and $G \sqsubseteq F$. It suffices to show that G is saturated. Suppose not. Let $J \triangleright G$ be a k -chine. Let $E \in J - G$. Then $\{E\} \cup F$ is a k -chine, and $\{E\} \cup F \triangleright F$. I.e., F is not maximal, contrary to hypothesis. Whence G is a saturated k -chine with j vertices.

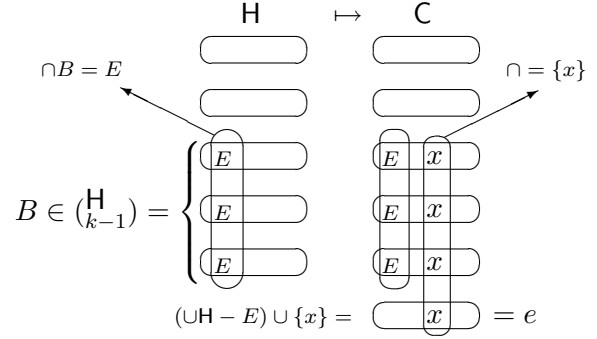

Figure 3: the construction of a saturated k -chine with j vertices from one with $(j - 1)$ vertices

References

- [1] C. Berge. *Hypergraphs: combinatorics of finite sets*. North-Holland. Amsterdam, 1989.
- [2] J. Boardman, J. Griffin, O. Murray (eds). *The Oxford History of the Classical World*. Oxford UP. Oxford, 1986.
- [3] R.E. Jennings. *suggested in conversation*.
- [4] R.E. Jennings, P.K. Schotch. On detouring. *Paraconsistent Logic, Philosophia*. Verlag. Munich, 1989.
- [5] T. Nicholson, R.E. Jennings, D. Sarenac. Revisiting completeness for the K_n modal logics: a new proof. *Logic journal of the IGPL*, 8(1): on-line, Jan 2000.

Research supported by the Natural Sciences and Engineering Research Council of Canada